



# CICLONE

## frullatori a immersione *hand-held mixers*



- Efficiente sistema di raffreddamento motore
- Robusta ma leggera struttura portante in ABS caricato a vetro
- Pratica ed ergonomica impugnatura
- Pulsante protetto per prevenire l'accensione accidentale
- Disponibile in due versioni di comandi:
- Velocità fissa
- **VT:** (Variotronic) variatore di velocità stabilizzato con controllo di potenza
- Macchina protetta con grado IP x3
- Rapido sistema di aggancio asta
- Disponibili aste da 25 e 35 cm
- Coltello a tre lame in acciaio da coltelleria
- Frusta con sistema di ingranaggi in metallo
- Fruste inox smontabili e pulibili in lavastoviglie

### Opzionali:

- Supporto pentola, supporto a muro, frusta
- Espositore inox

- *Efficient engine cooling system*
- *Sturdy, lightweight ABS frame Glass Filled*
- *Practical and ergonomic handle*
- *Push button safety system against accidental ignition*
- *Available in two versions of commands:*
- *Fixed speed*
- **VT:** *(Variotronic) speed control with stabilizer*
- *The machine is protected with IPX3*
- *Quick coupling system*
- *Shafts available in 25 and 35 cm*
- *Cutlery steel knives*
- *Whisk with metal gearing*
- *Whips Demountable and in the dishwasher*

### Options:

- *Pot support, wall attachment, whisk*
- *Display stand*



Espositore inox opzionale  
*Optional display stand*



Struttura autoportante con 3 espositori inox  
*Self-supporting structure with 3 display stands*



Griglie di ventilazione IP x3  
Air intake IP x3



Aggancio rapido utensili  
Quick tool assembly



Sgancio frusta  
Whisk release



Campana e coltelli inox  
Bell and knives of stainless steel



Supporto a filo opzionale  
Optional wall mount



Supporto a muro opzionale  
Optional wall support



Supporto pentola opzionale  
Optional bowl support

**VARI**TRONIC™  
SYSTEM

VT: Variatore di velocità stabilizzato  
con controllo di potenza

VT: Speed control with stabilizer



Asta 35  
Shaft 35



Asta 25  
Shaft 25



Frusta  
Whisk



Coltelli smontabili  
Removable knives

Asta smontabile  
Removable shaft

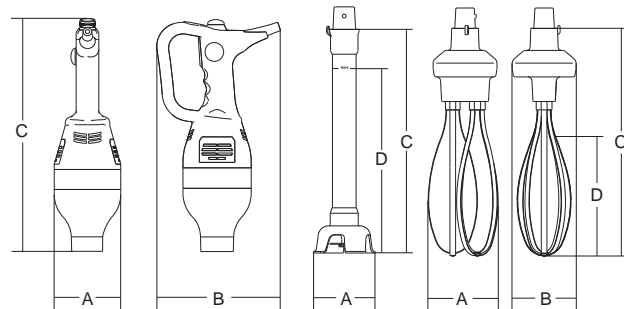

						A	B	C	D			
	watt/HP	1ph	r.p.m.	r.p.m.	lt	mm	mm	mm	mm	kg	mm	kg
Ciclone 20	200/0.27	1ph	2.300	16.000	20	100	182	340	-	2	440x330x150	3
Ciclone 20 VT	200/0.27	1ph	350÷2.450	2.300÷16.000	20	100	182	340	-	2	440x330x150	3
Ciclone 28	280/0.38	1ph	2.300	16.000	40	100	182	340	-	2.2	440x330x150	3.2
Ciclone 28 VT	280/0.38	1ph	350÷2.450	2.300÷16.000	40	100	182	340	-	2.2	440x330x150	3.2
Ciclone 36	360/0.50	1ph	2.300	16.000	70	100	182	348	-	2.5	440x330x150	3.5
Ciclone 36 VT	360/0.50	1ph	350÷2.450	2.300÷16.000	70	100	182	348	-	2.5	440x330x150	3.5
Asta 25	-	-	-	-	-	ø 94	-	250	190	0.5	320x210x220	1
Asta 35	-	-	-	-	-	ø 94	-	320	290	1	490x230x150	1.5
Frusta	-	-	-	-	-	106	113	348	165	2	520x210x250	3