

EKF 411 UD



ELECTRIC COMBI OVEN WITH MANUAL CONTROL



Handy use and quality. It heats ready meals but can also be used for preparing quick and simple deli recipes: it is the perfect ally for small food outlets where space is at a premium. Professional results and time optimization: compact and easy to use, it allows you to customize each recipe based on individual cooking requirements by exploiting the direct steam option. The EKF 411 UD, like all the ovens from the new Eka Evolution line, also gives a nod to energy saving with a new type of high-performance latest generation thermal insulation.

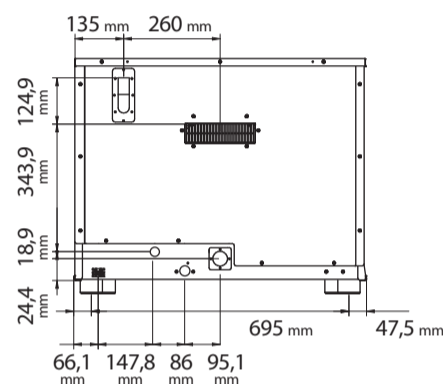
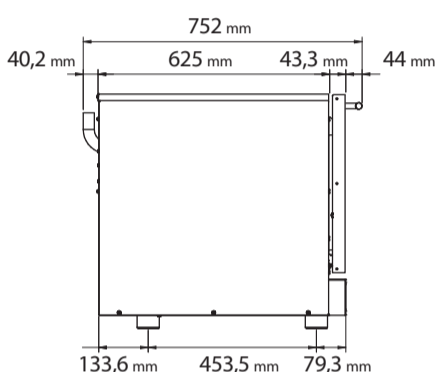
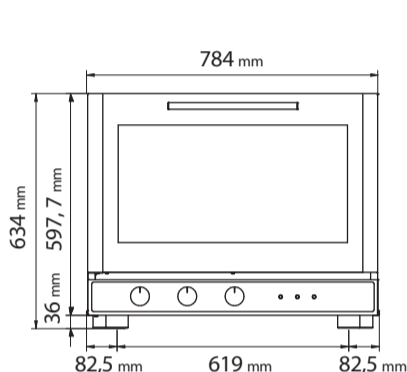

DIMENSIONAL FEATURES			
Oven dimensions EKF 411 UD (WxDxH mm)	784	752	634
Oven dimensions EKF 411 AL UD (WxDxH mm)	784	770	637
Oven weight EKF 411 UD (kg)	58		
Oven weight EKF 411 AL UD (kg)	56,4		
Distance between rack rails (mm)	73		

ELECTRICAL FEATURES	
Power supply (kW)	6,4
Frequency (Hz)	50 (60 on demand)
Voltage (Volt)	AC 380/400 2N
N° of motors	2 Bidirectional
Boiler	/
Protection against water	IPX3

EQUIPMENT			
Cardboard box dimensions with pallet (WxDxH mm)	805	830	800
Lateral supports	1 right + 1 left		
Cable	Two-phases + neutral [5G 2,5] - l=1600 mm		
Manual washing set up			

PLUS	
Stainless steel cooking chamber	
Door with inspectionable glass	
Quick fastening of lateral supports	
Embedded gasket	
Stackable	
Forced cooling system of inner parts	
IPX 3	
Manual washing set up	
New design of cooking chamber	
CB certification	
New design of handle	

FUNCTIONAL FEATURES	
Power	Electricity
Capacity	N° 4 trays/grids 1/1 GN
Type of cooking	Ventilated
Steam	Direct steam controlled by knob (5 levels)
Cooking chamber	AISI 304 Stainless steel
Temperature	100 + 260°C
Temperature control	Thermostat
Control panel	Electromechanic – Lower side
N° of programs	/
Programmable cooking steps	/
Pre-heating temperature	/
Pre-heating function	/
Door	Tilt door Ventilated Inspectionable glass
Modularity	Available

OPTIONAL	
Chromed grid 1/1 GN	KG9G
AISI 304 grid 1/1 GN	KG9GX
AISI 304 Tray 1/1 GN	KT9G
Smooth plate with non-stick coating 1/1 GN	KPGL11A
Striped plate with non-stick coating 1/1 GN	KPGR11A
Kit for overlapping ovens	Cod. EKKM4
Table	Cod. EKT 411 Cod. EKTR 411 Cod. EKTS 411 Cod. EKTRS 411 Cod. EKT 411 D
Condensation hood	Cod. EKKC4
Spray kit with support	Cod. EKKD
Air reducer	Cod. EKRP/A
Water tank lt. 7	Cod. EKSA
Pump kit with hose and filter	Cod. KKPU
Water softener - 8 Lt	Cod. KAF